



## **AERO-CELL™**

*High-Efficiency Fiberglass Rigid Air Filter*



### ***AERO-CELL Fiberglass Filter Features:***

- **High Density, Ultra-Fine Glass Filter Media In Class 1 and Class 2 Configurations**
- **Rating Up To MERV 14**
- **Corrosion-Resistant Galvanized Steel**
- **Rigid Internal Support**

# AERO-CELL™

High-Efficiency Fiberglass Rigid Air Filter

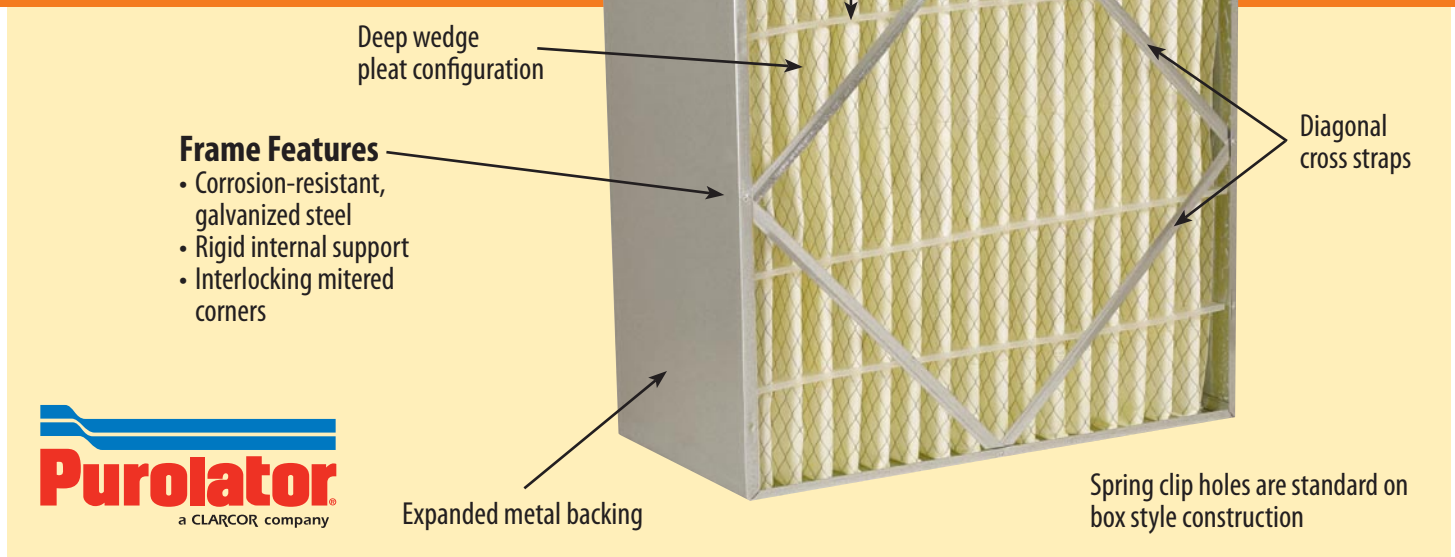

The AERO-CELL™ is a rigid air filter engineered to provide medium and high-efficiency filtration combined with a prolonged life cycle. Its box filter construction eliminates the need for retainers and special external wire media supports. A high surface area-to-depth ratio provides the maximum amount of effective filter media in areas of minimum in-line duct space. The result: A rigid, stable filter with consistent performance in a variety of operating conditions.

## Frame Construction

The AERO-CELL perimeter frame is constructed of high strength, corrosion-resistant, galvanized steel. To prevent air bypass, the filter pak is sealed to the frame on all sides. Filter integrity is maintained by pleat stabilizers which are bonded to both the air entry and air exit sides of the pak.

## Media and Backing

Each Purolator AERO-CELL filter utilizes a high-density filter media composed of ultra-fine glass fibers laminated to reinforced, high-strength nylon backing. The media is continuously bonded to expanded, corrosion-resistant, electro-galvanized steel which allows a 95% open face area.

## Fire Resistant Construction

Each AERO-CELL filter is constructed to meet Underwriters Laboratories, Inc. requirements for Class 2 air filters. Class 1 model also available where required.

## Pleat Configuration

To achieve a maximum dust holding capacity while minimizing pressure loss and replacement frequencies, the AERO-CELL incorporates aerodynamically wedge-shaped pleats into its design. The expanded metal backing and stationary pleat spacers allow consistent pleat configuration.

## Applications

The AERO-CELL is capable of withstanding 7.0" w.g. pressure drops without noticeable media-pak deterioration, and will operate to a final resistance of 1.5" w.g. Available in a variety of filtering efficiencies and sizes, the AERO-CELL will satisfy and effectively service most applications.

In Variable Air Volume (VAV) applications, the AERO-CELL maintains consistent filtering performance throughout a full range of velocities.

## Interchangeable

The AERO-CELL filter is designed to be completely interchangeable with all makes and types of medium to high-efficiency rigid cell filters. When used with Purolator conversion filter clips, existing side access and built-up filter banks are easily converted to support the AERO-CELL.

In high dust concentration applications, the life of an AERO-CELL is extended by the use of a prefilter. The Purolator MARK 80-D® and hi-E 40™ pleated filters have proven effective in such situations.

## Product Specification

Air filters shall be the high-efficiency, deep-pleated, disposable, rigid-cell type. The filter media shall be a high loft blanket composed of randomly oriented ultra-fine glass fibers laminated to a non-woven backing.

The filter media shall have an average efficiency of \_\_\_\_\_% and an arrestance of not less than \_\_\_\_\_% when tested in accordance with ASHRAE Test Standard 52.1. The dust holding capacity of the filter shall not be less than \_\_\_\_\_ grams. Each filter shall have a rated airflow of \_\_\_\_\_ cfm, and initial resistance not to exceed \_\_\_\_\_, and a final resistance of \_\_\_\_\_ w.g. Each filter shall have no less than \_\_\_\_\_ square feet of media area.

The filter media shall be continuously bonded to a heavy-duty, 28-gauge, corrosion-resistant, electrogalvanized steel, expanded metal grid with an open face area of not less than 95%.

To inhibit dirty air bypas, the media grid assembly

shall be bonded to all interior surfaces of the enclosure frame. The support grid shall be formed into a wedge configuration to optimize usage of the filter media. Pleat spacers shall be permanently installed.

The enclosure frame shall be constructed of corrosion-resistant galvanized steel in such a manner as to produce a rigid, durable filter. The filter shall be the AERO-CELL as manufactured by Purolator Air Filtration. Filters shall be listed and rated by Underwriters laboratories, Inc. as Class 2.

## Prefilters

Prefilters shall be the 2" or 4" medium efficiency (25 - 30%) pleated, disposable type, constructed with a non-woven cotton media supported by an expanded metal support backing and enclosed in a heavy duty, high wet strength board frame. The filter shall be the MARK 80-D® or hi-E 40™ type as manufactured by Purolator Air Filtration.

## Holding Frames

Holding frames shall be constructed of heavy duty, 16-gauge galvanized steel with flush-mitered, welded corners. The frame shall be supplied with closed cell eps/polyethyl/butyl gasket secured to the rear seating flanges of the frame. Each frame shall be supplied with positive sealing filter locks. The holding frames shall be the PURO® Frame type manufactured by Purolator Air Filtration.

## Side Access Housings

Housing shall be side-servicing from either end through access doors fitted with positive pressure trip lock latches and gasketed inside doors, parallel to the filter track. Housings shall be constructed of heavy duty 16-gauge galvanized steel. The housing shall be equipped with both a 2" prefilter track and a 1" final filter track. Each track shall be constructed of extruded aluminum combined with reinforced nylon pile air seals to create a corrosion-resistant, air-tight seal.

## Dimensions: Standard or Headered Filter Models

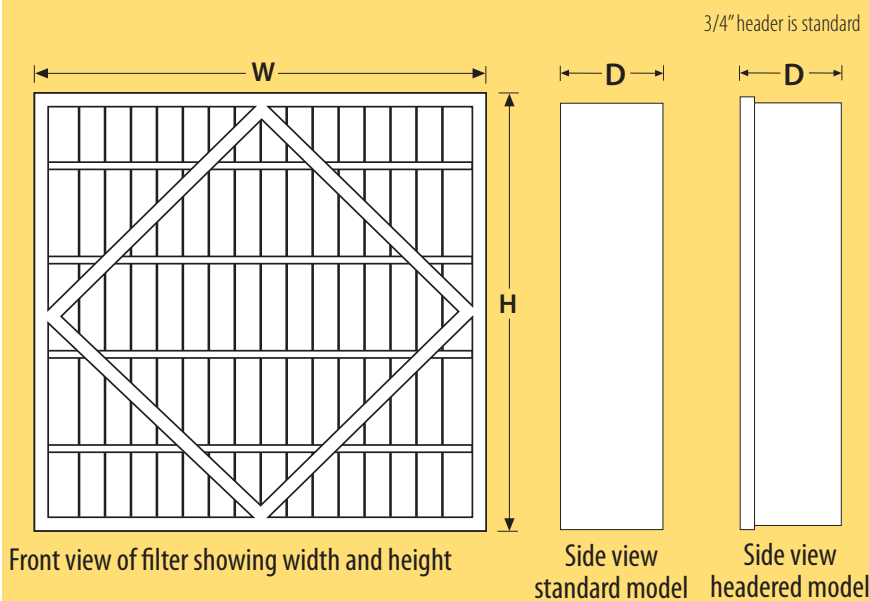

Size	Width	Height	Depth
12" x 24"	11-3/8"	23-3/8"	5-7/8" or 11-1/2"
20" x 24"	19-3/8"	23-3/8"	5-7/8" or 11-1/2"
24" x 24"	23-3/8"	23-3/8"	5-7/8" or 11-1/2"

\*Optional 1-1/8" header is available upon request

# AERO-CELL™

High-Efficiency Fiberglass Rigid Air Filter

Series	Nominal size WxHxD	Standard Models						Headered Models*			
		AERO-CELL Model number	CFM capacity		Resist. in. w.g.		Media area sq. ft.	AERO-CELL Model number	Resist in. w.g.		Media area sq. ft.
		number	med	high	med	high	sq. ft.	number	med	high	sq. ft.
<b>50%</b>	24x24x12	AC50-4412	1000	2000	.08	.25	58	HAC50-4412	.10	.32	50
	20x24x12	AC50-0412	850	1700	.08	.25	47	HAC50-0412	.10	.32	40
	12x24x12	AC50-2412	500	1000	.08	.25	29	HAC50-2412	.10	.32	25
	24x24x6	AC50-4406	500	1000	.04	.13	29	HAC50-4406	.05	.15	26
	20x24x6	AC50-0406	425	850	.04	.13	24	HAC50-0406	.05	.15	21
	12x24x6	AC50-2406	250	500	.04	.13	15	HAC50-2406	.05	.15	13
<b>65%</b>	24x24x12	AC60-4412	1000	2000	.10	.30	58	HAC60-4412	.13	.40	50
	20x24x12	AC60-0412	850	1700	.10	.30	47	HAC60-0412	.13	.40	40
	12x24x12	AC60-2412	500	1000	.10	.30	29	HAC60-2412	.13	.40	25
	24x24x6	AC60-4406	500	1000	.05	.15	29	HAC60-4406	.06	.17	26
	20x24x6	AC60-0406	425	850	.05	.15	24	HAC60-0406	.06	.17	21
	12x24x6	AC60-2406	250	500	.05	.15	15	HAC60-2406	.06	.17	13
<b>85%</b>	24x24x12	AC85-4412	1000	2000	.25	.50	58	HAC85-4412	.28	.65	50
	20x24x12	AC85-0412	850	1700	.25	.50	47	HAC85-0412	.28	.65	40
	12x24x12	AC85-2412	500	1000	.25	.50	29	HAC85-2412	.28	.65	25
	24x24x6	AC85-4406	500	1000	.10	.30	29	HAC85-4406	.15	.35	26
	20x24x6	AC85-0406	425	850	.10	.30	24	HAC85-0406	.15	.35	21
	12x24x6	AC85-2406	250	500	.10	.30	15	HAC85-2406	.15	.35	13
<b>95%</b>	24x24x12	AC95-4412	1000	2000	.30	.65	58	HAC95-4412	.35	.80	50
	20x24x12	AC95-0412	850	1700	.30	.65	47	HAC95-0412	.35	.80	40
	12x24x12	AC95-2412	500	1000	.30	.65	29	HAC95-2412	.35	.80	25
	24x24x6	AC95-4406	500	1000	.25	.50	29	HAC95-4406	.30	.60	26
	20x24x6	AC95-0406	425	850	.25	.50	24	HAC95-0406	.30	.60	21
	12x24x6	AC95-2406	250	500	.25	.50	15	HAC95-2406	.30	.60	13

\* Standard Header is 3/4"; a 1-1/8" header is available.

The following non-standard sizes are available upon request: 20x20x12, 16x20x12, 20x25x12, and 16x25x12. Class 1 available where required.

Filtering Efficiencies			
Model	Average Efficiency	Average Arrestance	MERV Rating
50	45-50%	96%	---
65	60-65%	97%	12
85	80-85%	98%	13
95	90-95%	99%	14

P-AERO-407



[www.purolatorair.com](http://www.purolatorair.com)



CLARCOR Air Filtration Products

P. O. Box 32578 • Louisville, KY 40232

Customer Service Team: 1-866-925-2247 • Fax: 1-800-784-3458

Email: [info@purolatorair.com](mailto:info@purolatorair.com) • [www.purolatorair.com](http://www.purolatorair.com)

Distributed by:

© 2007 CLARCOR Air Filtration Products. CLARCOR Air Filtration Products has a policy of continuous product research and development and reserves the right to change design and specifications without notice.